

User Manuel

SQM33...



**Servomotor
(Actuator)**

English

The actuators of the SQM33... range are used to drive and position gas dampers, air dampers, oil control valves or other ancillary equipment.

When used in connection with burner controls or electronic fuel / air ratio control, the controlling elements are operated depending on the burner's current output.

Warning notes

To avoid injury to persons, damage to property or the environment, the following warning notes must be observed!

Do not open, interfere with or modify the actuators!

- All activities (mounting, installation and service work, etc.) must be performed by qualified staff
- Before making any wiring changes in the connection area of the units, completely isolate the equipment from mains supply (all-polar disconnection). If not observed, there is a risk of electric shock hazard
- Ensure protection against electric shock hazard by providing adequate protection for the connection terminals and by securing the housing cover
- Each time work has been carried out (mounting, installation, service work, etc.), check to ensure that wiring is in an orderly state
- Fall or shock can adversely affect the safety functions. Such units must not be put into operation, even if they do not exhibit any damage
- The notes in chapter Section of actuator version, Positive connection and Unambiguous assignment must be observed, for safeguarding of correct fuel / air ratio The actuator's housing must not be opened. The actuator contains an optical feedback system

Selection of actuator version

Select the type of actuator depending on the torque required for driving the controlling element

- Ensure that any other torque acting on the controlling element (e.g. torque due to the airflow produced by the burner's fan) is smaller than the actuator's self-holding torque when dead
- The mechanical design of the burner must be such that any inadmissibly high torque from outside acting on the controlling element will not lead to critical burner operation.

Example: The airflow in the burner's air duct exerts a torque on the air damper's asymmetrical bearing so that the air damper will slightly travel towards the fully open position. This leads to a certain amount of excess air in the combustion process, which is less critical than lack of air

Mounting notes

Possible connection with drive shaft or hub:

- Drive shaft with flat edge and matching counter piece
- To avoid inadmissible loads on the bearing caused by rigid coupling hubs, Siemens recommends using compensating coupling without mechanical play (e.g. metal bellows coupling).
- When sizing a drive shaft connection, consider that – during operation – the effective torque can exceed the actuator's rated torque:
- Under optimum operating conditions, the actuator may deliver a higher torque
 - Mass moments of inertia (produced by rotating motor compo-

nents and on the controlling element) can lead to sudden peak loads

- Siemens recommends to adequately oversize the drive shaft connection in relation to the actuator's rated torque
- The connection between actuator and burner or controlling element must be very rigid (no bending). This is of particular importance when using structures incorporating columns

Unambiguous assignment

To prevent mix-up of actuators connected to the LMV2... / LMV3..., these types of burner controls carry various reference marks.

The burner must be designed such that, in the event of false connections, the relevant reference mark cannot be approached. For that purpose, mechanical stops are to be provided in the range «Stop open» and «Stop closed».

Cable

SQM33.41... / SQM33.51...:

- The actuators are supplied complete with attached connecting cable and plug.

SQM33.550A9:

- The actuators are supplied with cable ready connected, complete with ferrules
- The 6-poles RAST3.5 connecting plug (included in scope of delivery)
- One-time bend when laying the cable: 2 x cable diameter

IP54

To ensure degree of protection IP54 over the actuator's entire service life, the bearing of the drive shaft must be located such that it will not be directly exposed to water or dust.

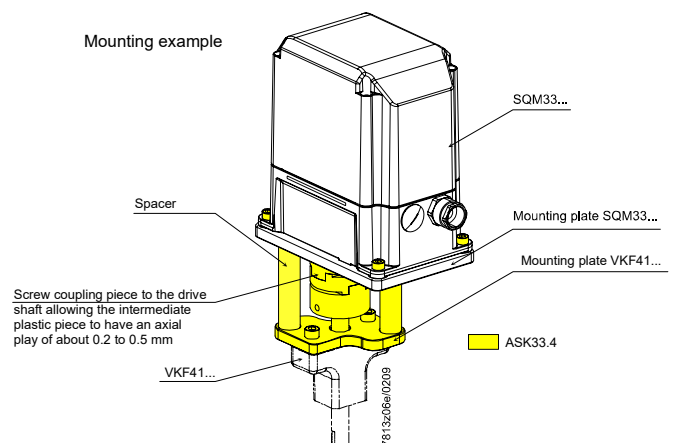

Working range of actuator

The actuator's working range consists of usable range and reference range. The usable range is specified on the type field. When mounting the actuator, the connected controlling element (e.g. air damper) must allow travel both in the reference range and the adjusted usable range. Reference ranges «Open» and «Close» differ. In the case of an actuator with counterclockwise direction of rotation, reference range «Close» lies between 0° and -7.7°, and reference range «Open» between 90° and 110.6°. To ensure precise positioning of the actuator on the burner, a positioning pin of 6 mm dia. must be fitted to the mounting surface (refer to detail A under «Dimensions»).

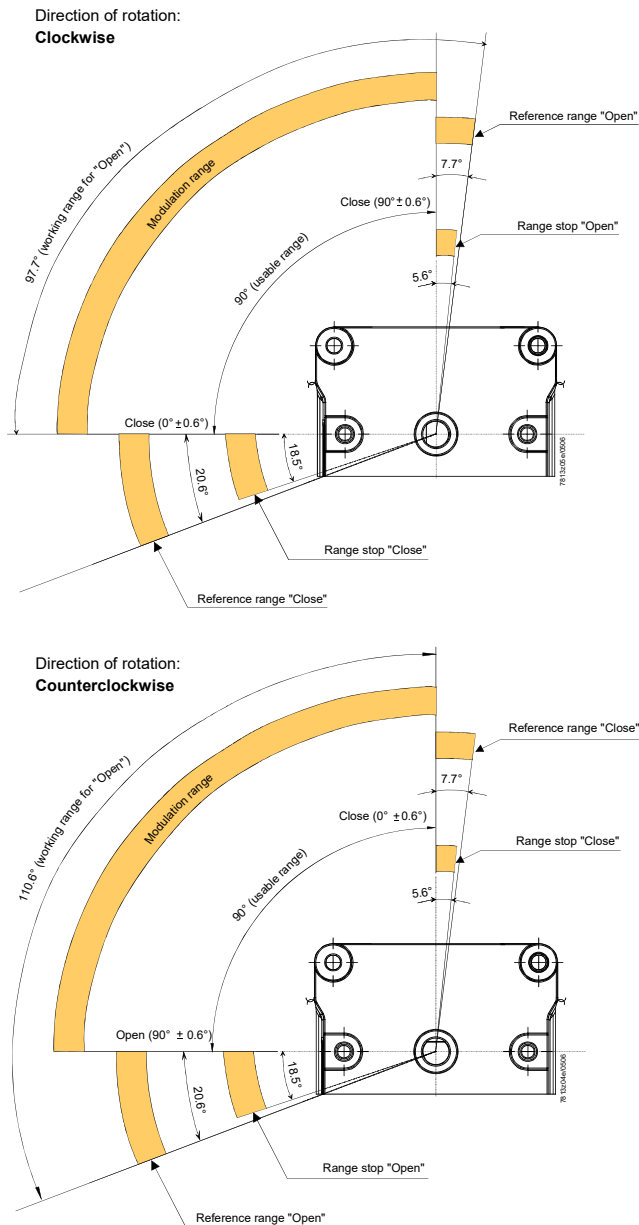

Installation notes

- Always run the high-voltage ignition cables separate from the unit and other cables while observing the greatest possible distance
- The holding torque is reduced when the actuator is disconnected from power

Service notes

When replacing an actuator, the following points must be checked and, if necessary, corrected:

- Correct connection of the basic unit
- Assignment of functions
- Adjustment of curve points of electronic fuel / air ratio control (e.g. with the LMV27...)

Disposal notes

The actuator contains electrical and electronic components and must not be disposed of together with domestic waste. Local and currently valid legislation must be observed.

Mechanical design

Housing: The housing is made of die-cast aluminium.
The cover is made of impact-proof and heat-resistant plastic.

SQM33.550A9 has a flange for the connection of a Conduit connecting thread (NPSM ½" -14).

Color of cover: Black

Actuator: Stepper motor

Adjustment of switchingpoints / position indication: In connection with the basic unit (e.g. LMV27...): Via the AZL2... display and operating unit (refer to the Basic Documentation of the LMV27...).

Cable / electrical connections: SQM33.41xA9 and SQM33.51xA9 only: RAST2.5 connectors complete with cable. SQM33.550A9 only: Cable with ferrules, RAST3.5 connector (included in scope of delivery).

Gear train: Spur gears made of steel and plastic, with little backlash and permanent lubrication.

Drive shaft: Made of black-finished steel, ready fitted to the front of the gear train.

Mounting and fixing: The front of the gear train is used as the mounting surface. The actuator has 4 fixing holes and an elongated hole for the positioning pin. Alternatively, the actuator can be secured with 3 self-tapping screws from the side of the controlling element.

Actuators SQM33...

Type	Rated output torque (max.) Nm	Holding torque when live (max.) Nm	Holding torque when dead (max.) Nm	Cable length m	Radial load on bearing middle of drive shaft (max.) N	Axial load on bearing middle of drive shaft (max.) N
SQM33.410A9	1,2	1,2	0,8	1,5	100	10
SQM33.411A9	1,2	1,2	0,8	3	100	10
SQM33.510A9	3	3	2,6	1,5	100	10
SQM33.511A9	3	3	2,6	3	100	10
SQM33.550A9	3	3	2,6	3,6	100	10

Selkoc

Isıtma & Soğutma Otomasyon San. Tic. Ltd. Şti.

+90 (555) 994 13 62
+90 (212) 501 48 54 - 55
+90 (212) 501 48 57

info@selkoc.com.tr
satis@selkoc.com.tr
export@selkoc.com.tr

İsmetpaşa Mah. Hisar Sk. No:20/53-59
Üstün İş Merkezi Bayrampaşa / İstanbul / Turkey